

FENCING
STANDARDS
FOR
POOLS

7 January 2010

TABLE OF CONTENTS

INTRODUCTION	1
EXISTING SWIMMING POOLS	2
NEW SWIMMING POOLS	2
Spa Pools	3
Indoor Swimming Pools	3
RESUSCITATION NOTICE	3
EXEMPTIONS	4
WHAT ARE THE STANDARDS?	4
POOL FENCING	4
General	4
DESIGN AND CONSTRUCTION OF POOL FENCING	5
General	5
Materials	5
Fencing Height	5
Ground Clearance	7
Outside Surface	7
Horizontal Climbable Members	8
Horizontal Non-Climbable Members	8
Horizontal Surfaces Inside The Fencing	10
Vertical Members	10
Other Forms Of Barriers	11
Protection of Windows	11
GATES AND FITTINGS	12
Gates	12
Direction of Opening	12
Automatic Closing Device	12
Latching Device	12
Location of the Latching Device	13
Shielding of Latching Device	13
BALCONIES	14
EXAMPLES OF POOL FENCING LOCATIONS	16

INTRODUCTION

The Swimming Pools Act, 1992 and Regulations sets out the standards to restrict access to private swimming pools.

The Act has separate requirements for both existing and new swimming pools. Existing pools are those constructed prior to 1 August 1990 and new pools are those constructed after 1 August 1990, or proposed to be constructed.

Swimming Pools that are completed or constructed after 1 September 2008, are required to comply with the Swimming Pools Regulation 2008 and Australian Standard 1926.1 – 2007 Part 1: Safety Barriers for Swimming Pools.

From 1 July 2010, the swimming pool barrier must be located immediately around the swimming pool, and must not contain within its bounds any structure apart from the swimming pool and such other structures (such as diving boards and pool filtration plants) as are wholly ancillary to the swimming pool.

The following brochure sets out the requirements restricting access to new and existing pools.

For advice on any aspect of swimming pool safety please contact Council's Environment and Planning Team.

EXISTING SWIMMING POOLS

The Swimming Pools Act, 1992 requires that swimming pools constructed or installed prior to 1 August 1990, have either:

- 1) A child-resistant barrier (i.e. a fence) that separates the swimming pool from any residential building situated on the premises and from any other place adjoining the premises, or
- 2) A child-resistant barrier (i.e. a fence) surrounding the yard area together with the access restricted from the dwelling. The windows and doors granting access to the swimming pool are to be restricted in accordance with the standards prescribed by the regulations.

The Swimming Pools Act, 1992 requires that the owner of any premises on which a swimming pool was constructed or installed after 1 August 1990 and completed before 1 September 2008, must ensure that the swimming pool is at all times surrounded by a child-resistant barrier that:

- (a) Separates the swimming pool from any residential building situated on the premises and from any place (whether public or private) adjoining the premises; and
- (b) is designed, constructed, installed and maintained in accordance with the standards prescribed by the regulations.

NEW SWIMMING POOLS

The Swimming Pools Act, 1992 requires that the owner of any premises on which a swimming pool is proposed to be constructed or installed must ensure that the swimming pool is at all times surrounded by a child-resistant barrier that:

- (a) Separates the swimming pool from any residential building situated on the premises and from any place (whether public or private) adjoining the premises; and
- (b) is designed, constructed, installed and maintained in accordance with the standards prescribed by the regulations.

The Swimming Pools Regulation 2008 provides the general barrier requirements for outdoor swimming pools and for the purposes of Section 7 (1) (b) and 12 (d) of the Act, the prescribed standard for swimming pool barriers shall be AS 1926.1 – 2007 excluding Clause 2.8 of the standard. Clause 2.8 relates to child resistant doorsets which are considered inapplicable to the requirements to Section 7 of the Act.

Clause 2.8 of the standard is to be considered with respect to Sections 8, 9, 10 and 14 of the Act which relate to swimming pools commenced before 1 July 2010 located on very small properties, large properties, waterfront properties, or indoor swimming pools. In most cases, isolation fencing is still required to be installed.

Clause 2.10 of the standard is also excluded by the Swimming Pool Regulation 2008 as detailed in the definitions section of the regulation.

From 1 July 2010, the swimming pool barrier must be located immediately around the swimming pool, and must not contain within its bounds any structure apart from the swimming pool and such other structures (such as diving boards and pool filtration plants) as are wholly ancillary to the swimming pool.

What about Spa Pools? (Movable or Permanent)

A spa pool is not required to be surrounded by a child-resistant barrier so long as access to the water contained in the spa pool is restricted, in accordance with the standards prescribed by the regulations, at all times when the spa pool is not in actual use.

- The spa pool must be covered or secured by a child-safe structure, such as a lid, grille or mesh, that is fastened to the spa pool by a child-resistant device.

What about Indoor Swimming Pools?

- The owner of any premises in which an indoor swimming pool is situated must ensure that the means of access to the swimming pool is at all times restricted in accordance with the standards prescribed by the regulations.

RESUSCITATION NOTICE

In addition to safety fencing, the Swimming Pools Act 1992 requires that a warning notice be displayed, in a prominent position, in the immediate vicinity of the swimming pool, showing details of resuscitation techniques and bearing the statement:

- (i) Young children should be supervised when using the swimming pool; and
- (ii) Pool gates must be kept closed at all times; and
- (iii) Keep articles, objects and structures at least 900 millimetres clear of the pool fence at all times.

EXEMPTIONS

The following situations are exempt from the requirements **ONLY** where physical circumstances preclude the installation of a complete isolation barrier where:

- 1) Swimming pools the construction or installation of which commenced before 1 July 2010 that are situated on premises having an area of less than 230 square metres; OR
- 2) Swimming pools the construction or installation of which commenced before 1 July 2010 that are situated on premises of 2 hectares or more, or having frontage to any large body of water (such as a permanently flowing creek, a river, a canal, a pond, a lake, a reservoir, an estuary, the sea or any other body of water, whether natural or artificial).

WHAT ARE THE STANDARDS?

Australian Standard AS 1926.1 - 2007 titled "Swimming Pool Safety – Part 1: Safety Barriers for Swimming Pools" is the minimum acceptable standard for the construction of swimming pool fencing, excluding Clause 2.10 of the standard.

The Swimming Pools Act 1992 and the Swimming Pools Regulation 2008 sets the requirements for a complying child resistant barrier.

POOL FENCING

General

A fence is an effective means of restricting young children from gaining access to a pool. The location of the pool fence shall comply with any requirements of Council or State Government and both the fence and gate shall comply with AS 1926.1 - 2007.

The type of fence and the location of the pool within the fenced area shall permit viewing through or over the fence so that the pool area may be viewed from commonly used areas of the house or yard, etc.

It is recommended that the distance of fencing from the pool shall take into consideration a safety margin sufficient to discourage diving and jumping from the fence into the pool. The fence shall not be located so close to the pool as to discourage adults from making use of the area within the fence while supervising children in the pool.

The fence shall be located clear of any overhanging projections such as tree branches, a garage roof, etc, which could be used as a means of access over the fence. Steeply sloping sites may require special consideration.

The owner of the premises may, subject to the requirements, determine where the fencing is to be located.

Note: Swimming pools shall be fenced independently of any driveway or vehicle access.

DESIGN AND CONSTRUCTION OF POOL FENCING

General

Fences and gates shall be designed and constructed so as to present an effective barrier to small children. The design and constructional requirements specified are aimed at inhibiting access under, over or through the fencing. The fencing requirements shall apply throughout the life of the swimming pool. The same standard of pool safety fences and gates shall be provided regardless of whether an in-ground or an above-ground pool is installed. The fencing and gates are to comply with the requirements of AS 1926.1 – 2007, excluding Clause 2.10 of the Standard.

Materials

All constructional materials concerned with safety aspects of the fencing shall be of a durable nature and satisfactory for their intended purpose under the conditions prevailing at the site. Materials that could be damaged by tearing, stretching, piercing or cutting shall not be used in locations where such damage would result on a lowering of the effectiveness of the fencing or the creation of a safety hazard to pool users.

Fencing Height

Fences and gates should have an effective height of at least 1.2 metres and shall include a continuous **Non-Climbable Zone (NCZ)**. The NCZ may be located anywhere on the vertical face of the fence. In this zone the distance between any hand and foothold shall be not be less than 900mm. (see figure 2.1).

Figure 2.1:

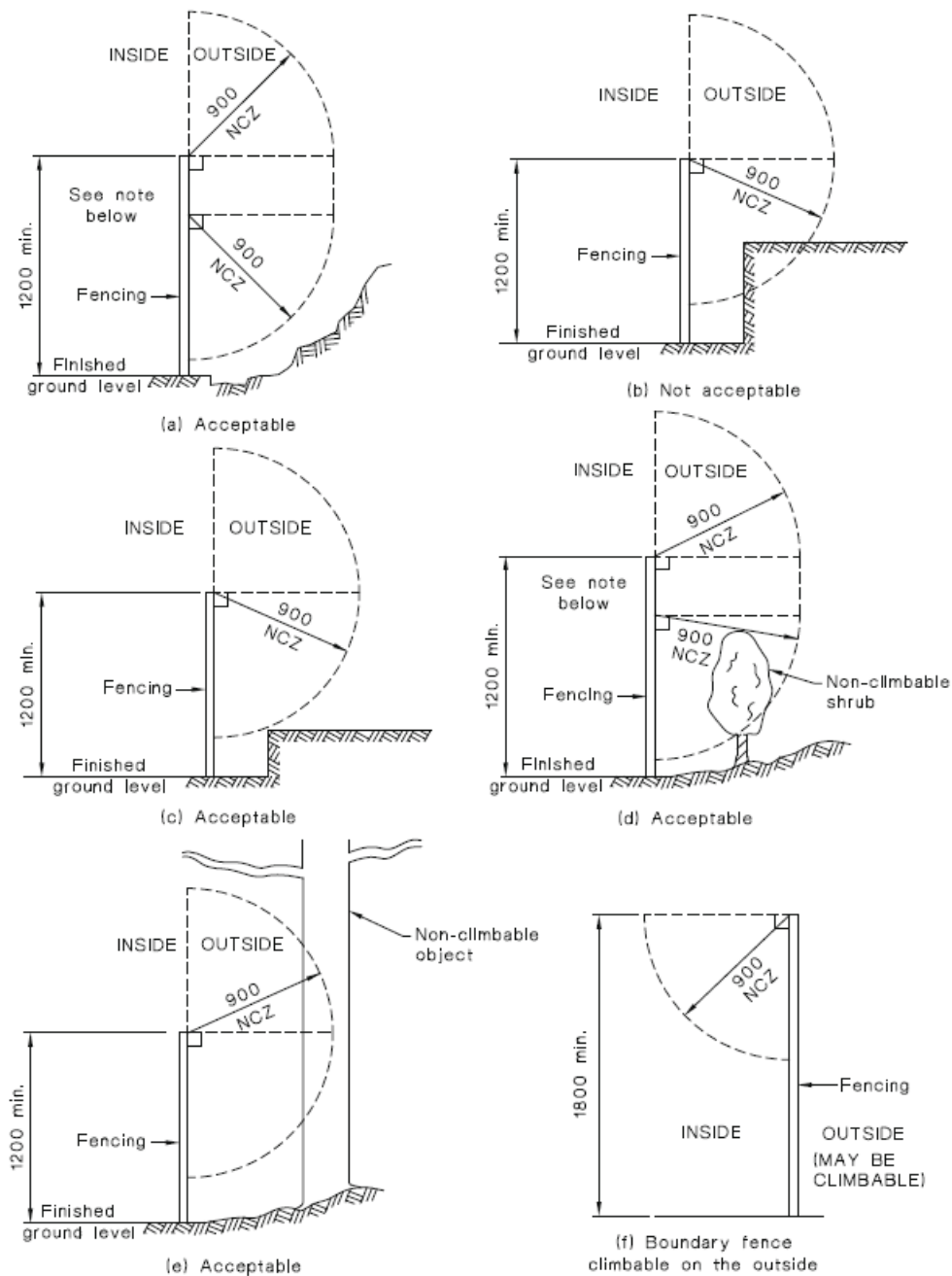

NOTE: The lower radius point may be anywhere on the fence at least 900 mm above the ground or the highest lower rail or foothold.

DIMENSIONS IN MILLIMETRES

FIGURE 2.1 EXAMPLES OF NON-CLIMBABLE ZONES/NCZs

Fences using perforated materials or mesh, with apertures not greater than 13mm shall have an effective height not less than 1200mm.

Fences using perforated materials or mesh with apertures greater than 13mm but not greater than 100mm shall have an effective height not less

than 1800mm. Fencing using mesh shall include a strainer wire or rail at the top and bottom of the fencing.

Ground Clearance

The height of any opening between the bottom of the fencing and finished ground level shall not exceed 100 mm.

Outside Surface

Projections from, or indentations into, the outside surface of the fence or gate, or any combination of projections and indentations, within the NCZ shall not form a substantial horizontal surface having a depth greater than 10 mm, unless they are spaced at least 900 mm apart. (see figures 2.3A and 2.3B).

Figure 2.3A

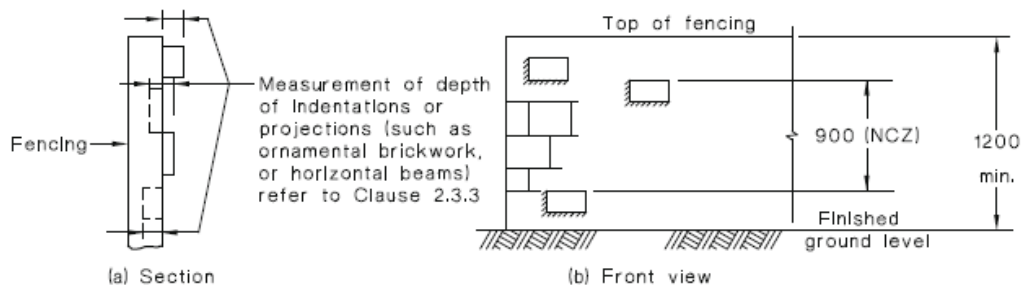

NOTE: The 900 NCZ may be between any two (2) points at any level on the outer face of the wall.

FIGURE 2.3(A) FENCING WITH PROJECTIONS SUCH AS ORNAMENTAL BRICKWORK OR STONEWORK

Figure 2.3B

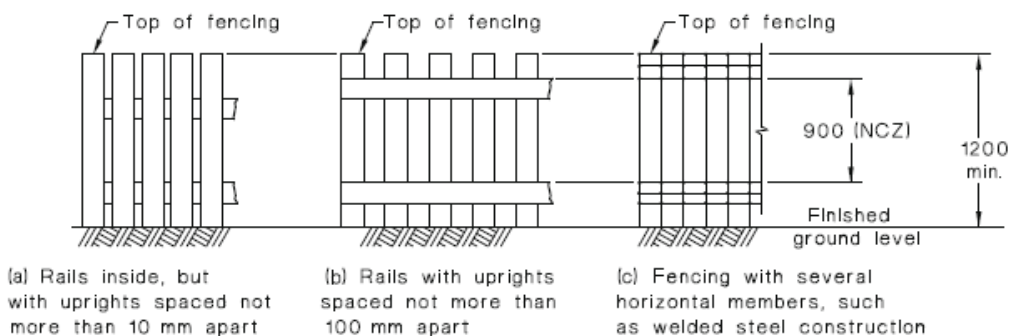

FIGURE 2.3(B) SPACING OF ACCESSIBLE HORIZONTAL MEMBERS, OR PROJECTIONS INDENTATIONS

Horizontal Climbable Members

For fences less than 1800mm in height, which include components such as rails, rods, wires, bracing or gate hinges that are located on the outside of the fencing and which could be used as holds for climbing, or where vertical members are spaced such that they provide clear openings more than 10mm in width, then the following shall apply:

- (a) Horizontal members shall not be within the non climbable zone. Where the fence is for a sloping site, the non-climbable zone shall be parallel to the top of the fence (see figure 2.2(a)).
- (b) For fences with rails, the top surface of the highest lower horizontal member shall be at least 1000mm below the top of the fence (see figures 2.2 and 2.3(B)).

Note: For fences less than 1800mm in height, substantially horizontal surfaces such as rails, rods, wires or bracing that could be used as holds for climbing, and which comply with the Items (a) and (b), should be located on the inside of the fence.

Horizontal Non-Climbable Members

As an alternative, substantially horizontal members, such as rails located on the outside of fencing less than 1800mm high, shall not be considered to act as a hold for climbing provided they comply with the following:

- (a) Horizontal members shall comply with figure 2.4, and
- (b) Vertical members shall be spaced to provide a clear opening of not more than 10mm.

Figure 2.2 in part

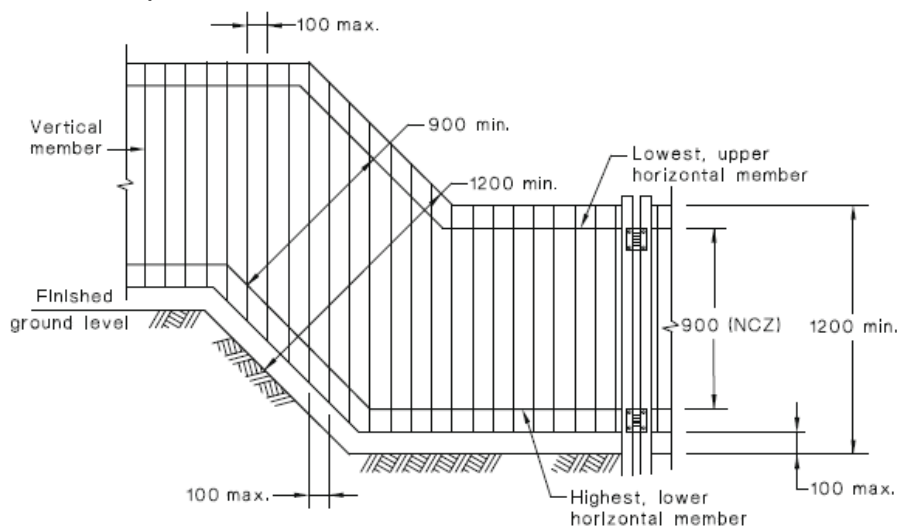

NOTE: On sloping sites, the fence height is to be measured perpendicular to the ground line.

(a) Sloping ground

Figure 2.2 in part

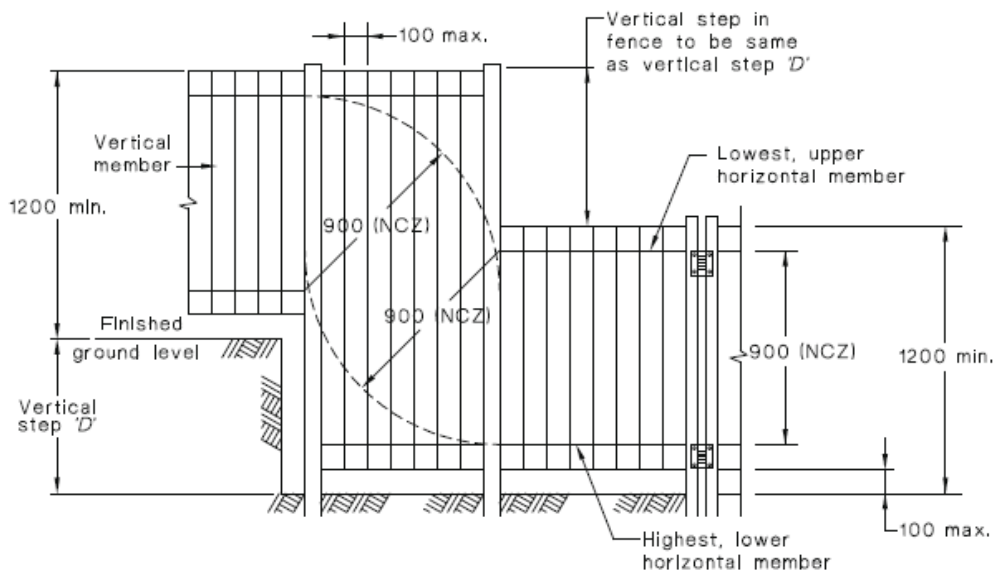

(b) Stepped ground

DIMENSIONS IN MILLIMETRES

FIGURE 2.2 (in part) PERPENDICULAR FENCING DIMENSIONS

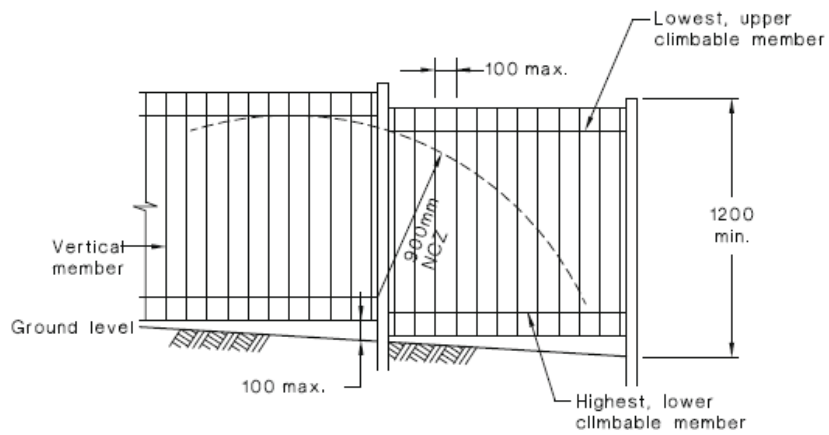

(c) Slightly sloping ground

DIMENSIONS IN MILLIMETRES

FIGURE 2.2 (in part) PERPENDICULAR FENCING DIMENSIONS

Figure 2.4

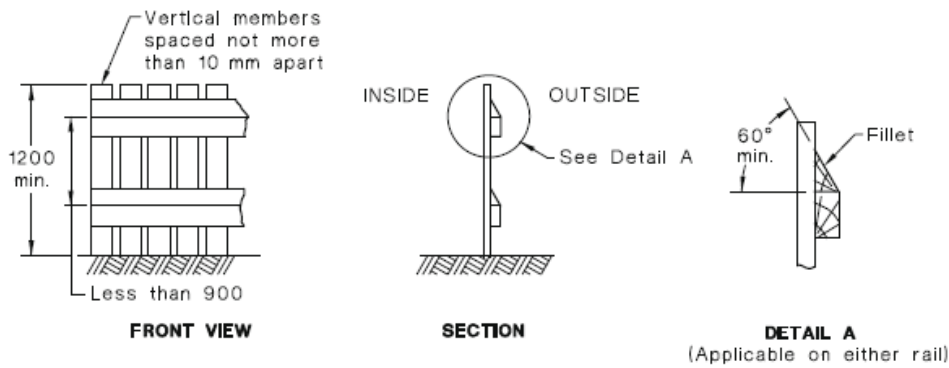

FIGURE 2.4 FENCE WITH HORIZONTAL MEMBERS PROJECTIONS OR INDENTATIONS NOT ACTING AS A HOLD FOR CLIMBING

Horizontal Surfaces Inside the Fencing

For fences less than 1800mm in height, where any nearby horizontal surfaces that could be used as holds for climbing are permanently located near the inside of the fencing adjacent to the NCZ, and where the spacing between the vertical members is greater than 10mm, such surfaces shall be separated from the fencing by a distance of not less than 300mm (see figure 2.5).

Figure 2.5

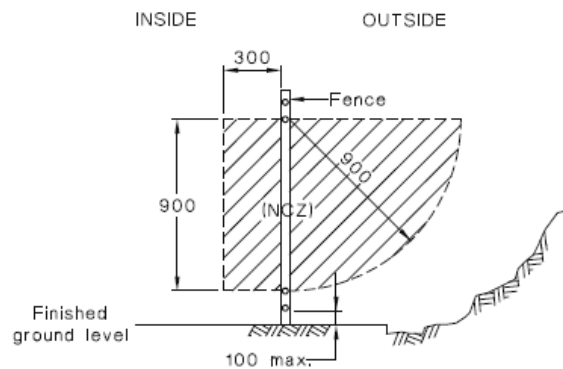

FIGURE 2.5 FENCING WITH HORIZONTAL MEMBER PROJECTIONS OR INDENTATIONS THAT MAY ACT AS A HOLD FOR CLIMBING

Vertical Members

The clear space between any adjacent vertical members (see figure 2.2), such as palings, rods or wires, shall not exceed 100mm at any point.

Other Forms of Barriers

A child-resistant barrier that is formed by, or that includes, a wall of a residential building, is regarded as separating any outside swimming pool from the residential building so long as:

- (a) The wall contains no door, window or other opening through which access may at any time be gained to the swimming pool; and
- (b) The wall is designed, constructed, installed and maintained in accordance with the standards prescribed by the regulations.

Protection of Windows

Opening portions of windows shall be protected where the sill height of the lowest opening panel of the window is less than 1800mm from the ground level (see figure 2.8), by one of the following means:

- (a) Where the sill height of the lowest opening panel of the window is less than 900mm from the floor level, either:
 - (i) Cover the open-able portion with bars or a mesh screen that are fixed to the building with fasteners that can only be removed by the use of a tool such as a screwdriver or spanner. The bars or screen material must meet the strength and rigidity requirements of the Standard, or
 - (ii) Fix the windows to the building with fasteners that can only be removed by the use of a tool, so that the window can only open to a maximum of 100mm and comply with the strength and rigidity requirements of fencing openings in the Standard.
- (b) Where the sill height of the lowest opening panel of the window is between 900mm and 1200mm from the floor level, then the open-able portion of the window shall comply with (a) above, or shall be fitted with a securely fixed flyscreen that is fixed to the window or building with fasteners that can only be removed by the use of a tool.
- (c) A window with a sill height greater than 1200mm from the floor level is not required to comply with the above.

Figure 2.8

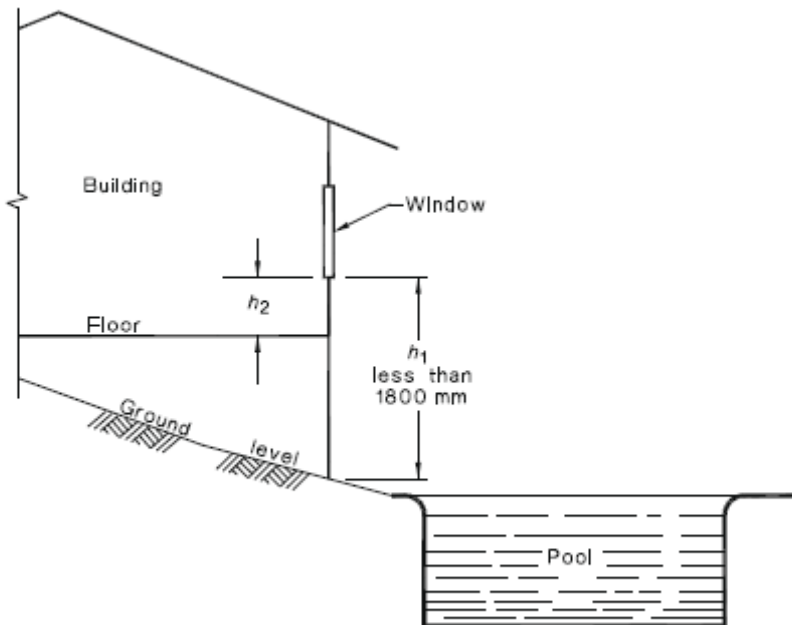

FIGURE 2.8 HEIGHT LIMITATIONS ON CHILD-RESISTANT WINDOWS

GATES AND FITTINGS

Gates

All gates shall be fitted with a self closing and self latching device and be capable of being opened from the pool side only.

Direction of Opening

Gates shall be mounted so that they swing outwards only, away from the pool area.

Automatic Closing Device

All gates shall be fitted with a device that will return the gate to the closed position and operate the latching device from any position with a stationary start, without the application of manual force.

The closing device shall be capable of complying with these requirements with the gate at any position, from resting on the latching mechanism to fully open.

Latching Device

An automatic self latching device shall be fitted preventing the gate from being re-opened without manually releasing the mechanism.

Location of the Latching Device

Where the release to the latching device is located at a height less than 1.5 metres above finished ground level and 1.4 metres above the highest lower horizontal member and is capable of being released at the latching mechanism, the location of the release of the latching device shall:-

- (a) Not be on the outside of the fencing;
- (b) Be in such a position that to release the latching mechanism from the outside, it will be necessary to reach over or through the fencing at a height greater than 1.2 metres above the finished ground level or not less than 1 metre above the highest lower horizontal member; and
- (c) Be at least 150 mm below the top of the gate if a hand-hole is not provided, or at least 150 mm below the edge of any hand-hole opening if a hand hole is provided.

Shielding of Latching Device

Where the release to either the latching device or the latch is located at a height less than 1.5 metres above the finished ground level and 1.4 metres above the highest lower horizontal member and is capable of being released at the mechanism, the latch and its release shall be so shielded that no opening greater than 10 mm occurs within an area bounded by:

- (a) An effective radius of 450 mm from the operating parts of the latch; and
- (b) The top of the fence, if this intersects the area described in (a).

Where it is necessary to have a hand-hole in a gate, the bottom of the opening shall be at least 1.2 metres above finished ground level, and 1 metre above the highest lower horizontal member, and the shielding shall be extended up to a horizontal line through the top of the hand-hole, or 150 mm above the top of the latch, whichever is the higher.

The shield shall be free of sharp edges and the edges of the adjacent parts of the shield on the gate and the fence shall be rounded or chamfered so as not to present a hazard when the gate closes. (see figure 2.6).

Figure 2.6

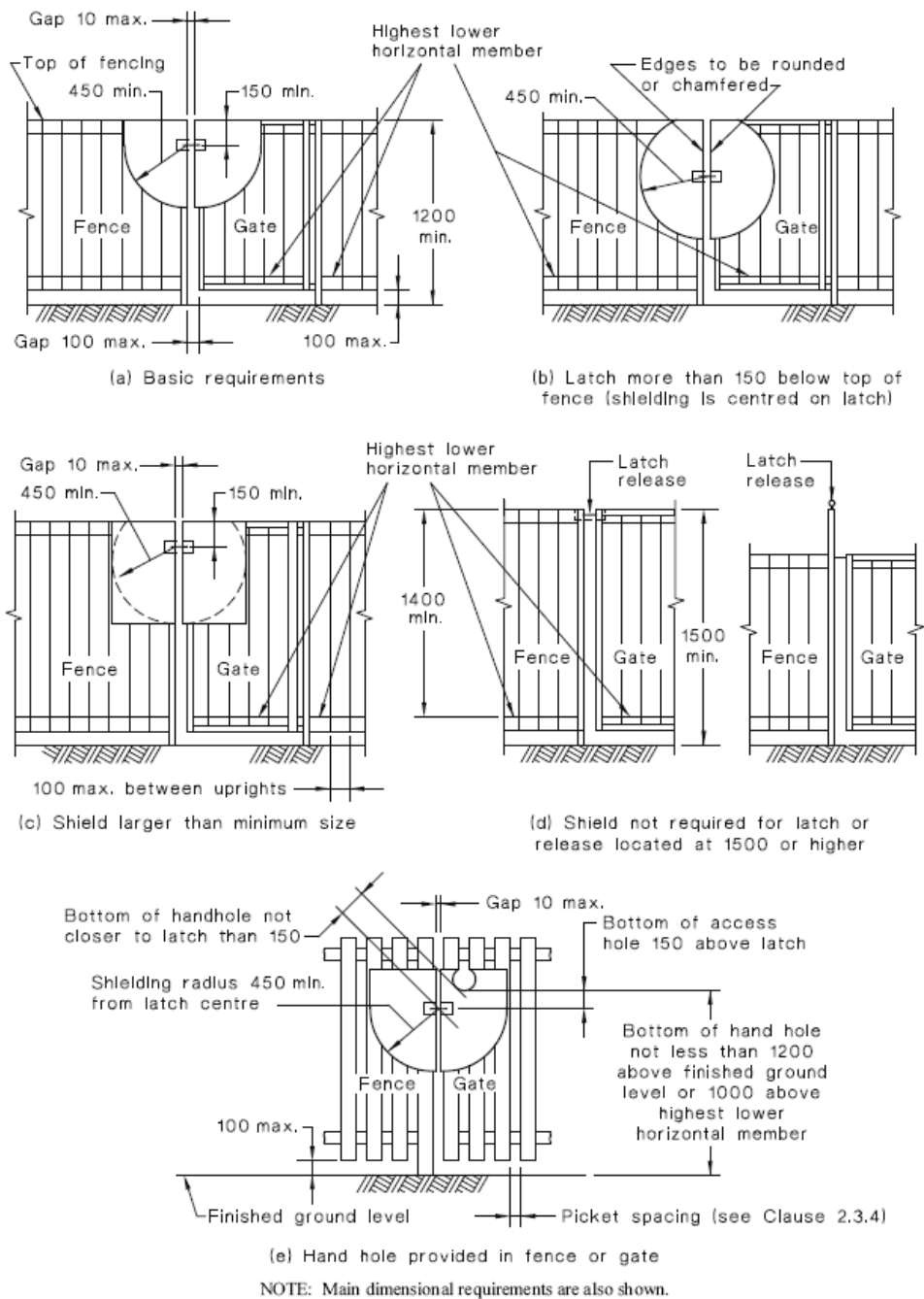

DIMENSIONS IN MILLIMETRES

FIGURE 2.6 ALTERNATIVE LATCH SHIELDING OPTIONS FOR GATES OF OPEN CONSTRUCTION

BALCONIES

A balcony shall include a balustrade that complies with the requirements for a barrier in the standard, where:

- (a) The balcony projects into the pool area, and where a distance (h^3) from the floor of the balcony to the finished ground level of the pool

area is less than 1800 mm, measured vertically below the perimeter balcony (see figure 2.9 (a)); or

- (b) Any part of the perimeter of the balcony floor is within 900mm of the top of the barrier (see figure 2.9(b)).

Figure 2.9

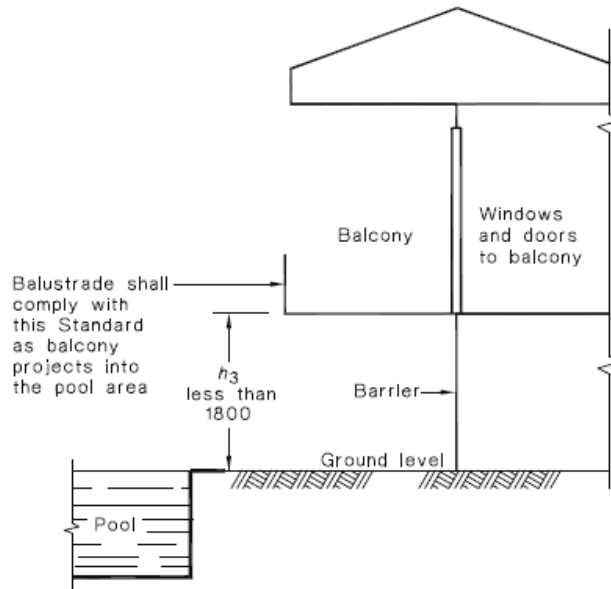

(a) Balcony projecting into pool area

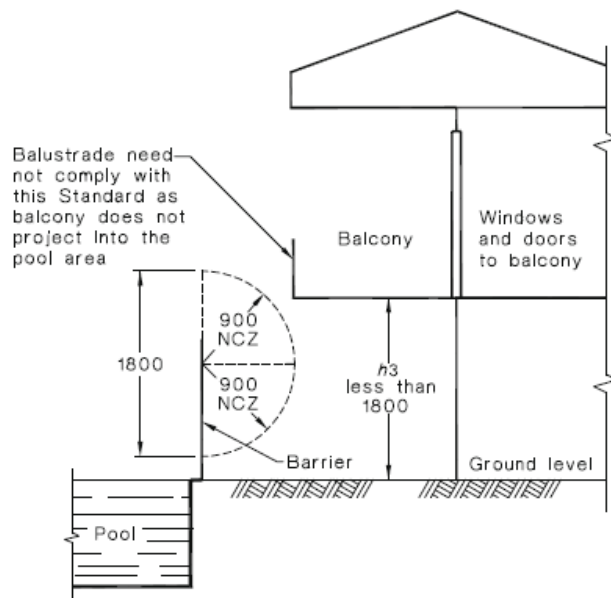

(b) Balcony adjacent pool area

NOTE: The lower radius point may be anywhere on the fence at least 900 mm above the ground or the highest lower rail or foothold.

DIMENSIONS IN MILLIMETRES

FIGURE 2.9 BALCONY AT POOL AREAS

EXAMPLES OF POOL FENCING LOCATIONS

Outdoor Pool for Residential Buildings

Figure 3: *Total Isolation Fencing*

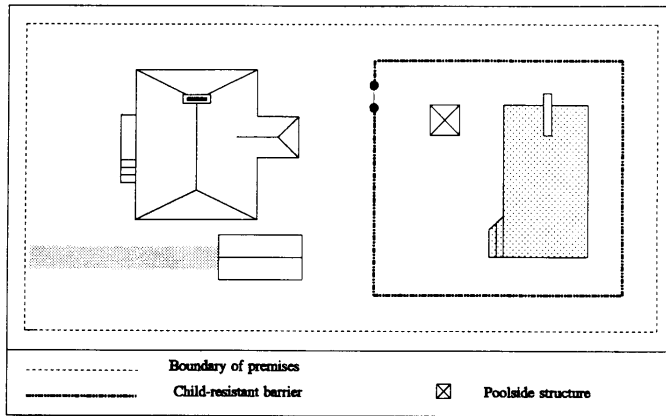
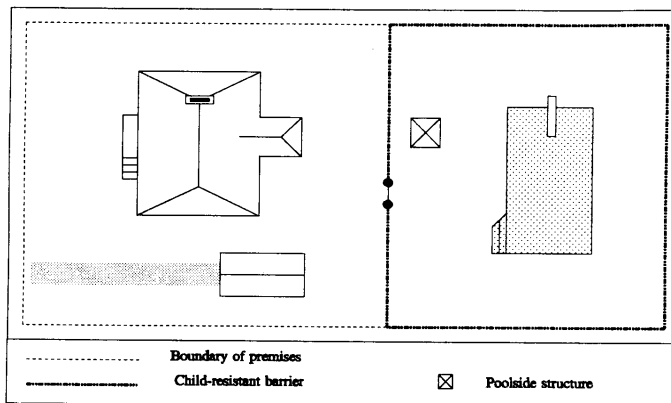

Figure 4: *Boundary fencing used together with a fence to isolate the pool from the dwelling.*
(Boundary fences used as part of the pool barrier must comply with AS 1926.1-2007)



Whilst the fencing standards will make a swimming pool secure, the responsibility for child safety and supervision remains with the swimming pool owner.

The Hills Shire Council gratefully acknowledges the assistance of Standards Australia.